



AUTO LOADING CNC LATHE

# GT FORCE-32

Specially suited for secondary operation  
of near net shape parts

 **CUBIC**  
MACHINERY

# GT FORCE-PP

## **GANG TOOL + AUTO LOADING = SMOOTH PRODUCTION FLOW**

Cubic Machinery has more gang tooled lathes than any other machine tool maker. GT Force continues in the tradition because of the inherent advantages provided by gang tool. We'll name 3 at the moment. First is a reduction of tool changing time. Second is a reduction of loading time. Third is improved accuracy due to less stack-up error, compared to typical lathe turrets. On the 3rd point, GT Force actually goes further because the Z-axis moves the headstock and X-axis moves the tool slide, we have even less stack-up error to contend with. These are the inherent qualities that make GT Force a natural choice when we pursue high speed, high precision, and superb finish as our machining goal. As a result, GT Force can hold 50 millionths of an inch accuracy. The accuracy is good enough that the lathe is suited for hard turning applications where the achievable finish and accuracy approaches or equals a grinding process.



# QUICK DELIVERY FROM PRE-ENGINEERED SOLUTIONS

Cubic Machinery has decades of experience building and deploying auto loaded lathes for customers. With the ever-rising labor cost, the demand for auto-loaded lathes has grown tremendously. We tap into our deep experience and distilled our know-how into the GT Force product range. They are pre-engineered solutions that we keep in stock regularly and enable customers can take delivery quicker.



With Epson N2 6-Axis Folding-Arm Robot

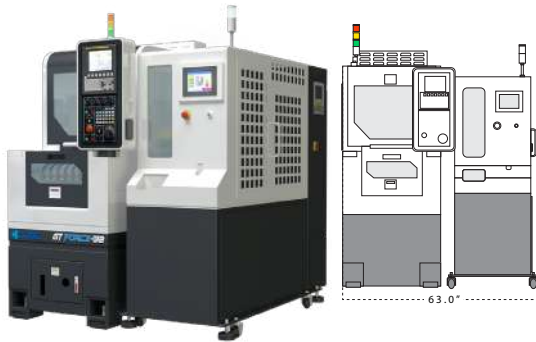

12 Station Rotary Stacker



In and Out Conveyors

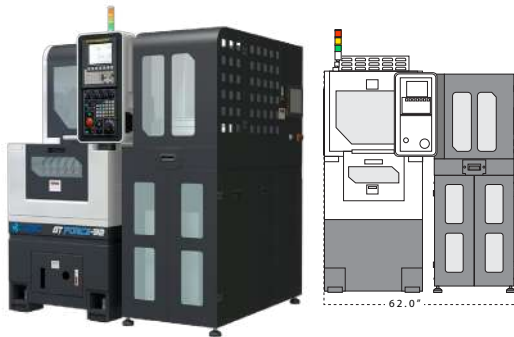

10 Tray Palletizer



Vibratory Bowl Part Feeder

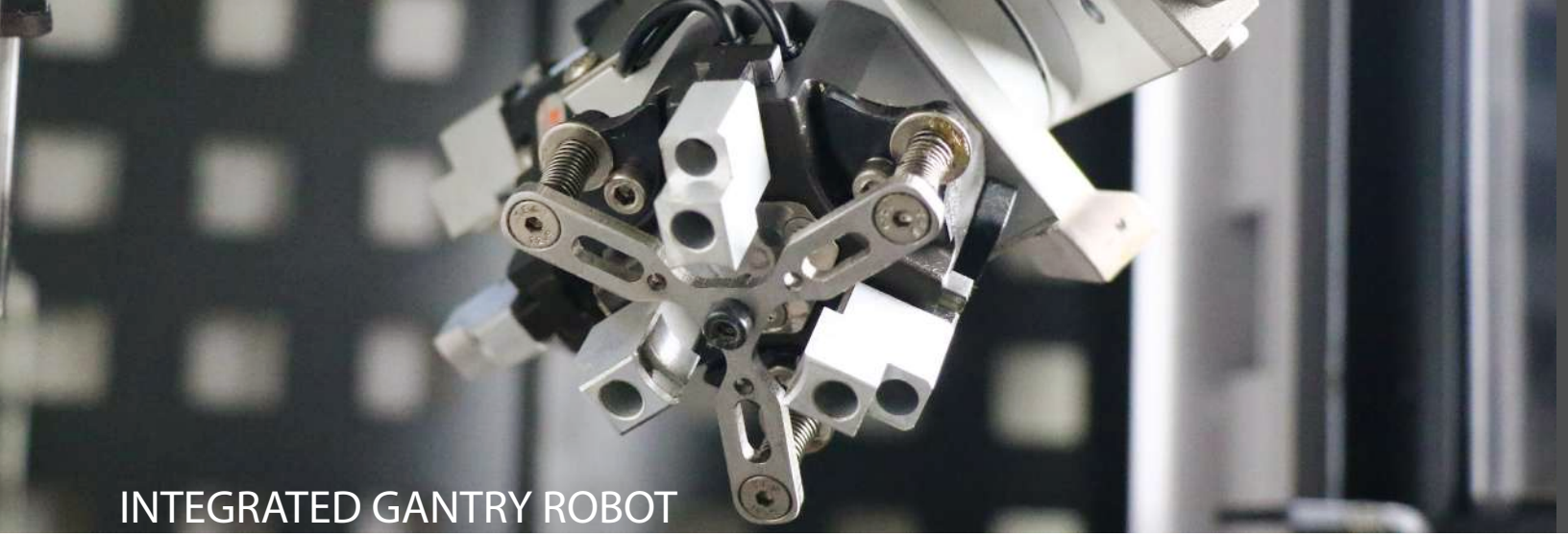

## INTEGRATED GANTRY ROBOT

GT Force series use FANUC 0i-TF control with 2-channel control. One channel is used to program the gantry robot. The integration makes it easy to program the gantry robot without the delays and synchronization problems commonly associated with using a separate controller for the robot.

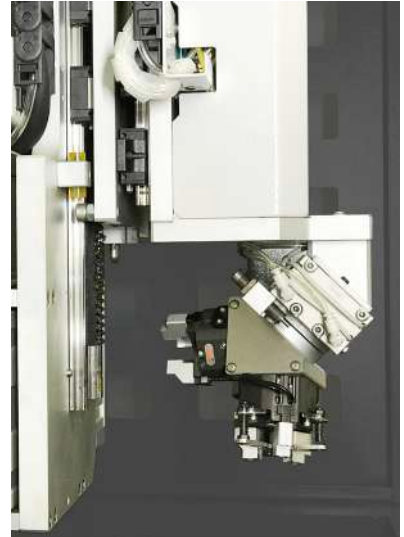

## MILLING AND OFF-CENTER DRILLING CAPABILITIES

GT Force is built with C-axis as standard equipment. A wide array of live tools are available to suit customer's application requirements. The C-axis has 0.08-degree accuracy. Combined with the 7.5HP spindle motor it can not only do simple milling and off-center drilling, it can also carry out XZC interpolation at very fast ramping speeds, which is required for features like helical keyway slotting. The capability which has been a signature feature on Cubic's GTV lathes is now available on GT Force.

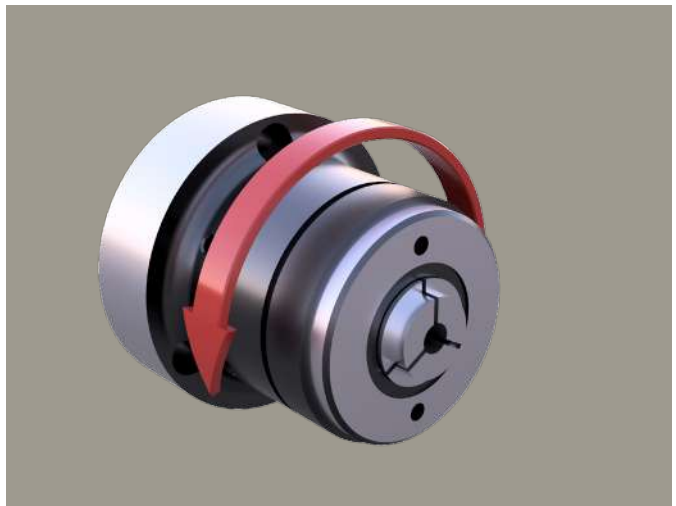

EXACT FIT: WE CAN TAILOR CHUCKING  
METHOD TO YOUR APPLICATION



SC Collet



Dead-Length Chuck (B30)



Hainbuch Id Mandrel

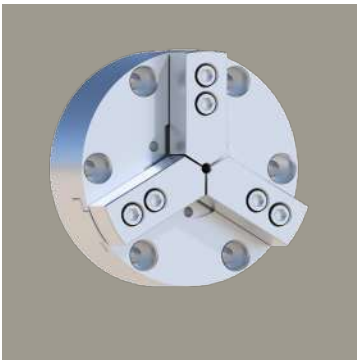

High Precision Air Chuck



5" Hydraulic 3-Jaw Chuck

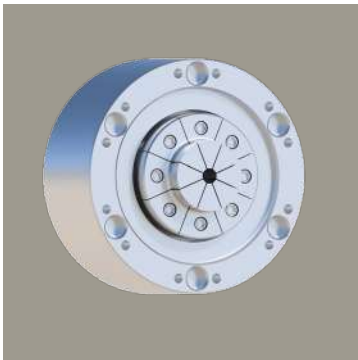

Diaphragm Chuck

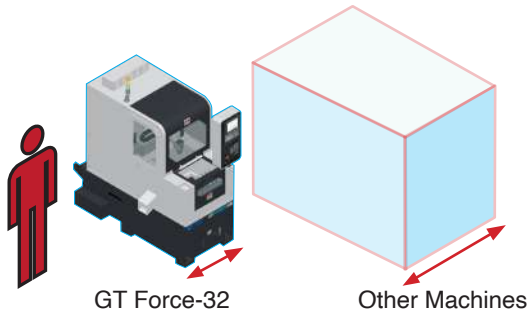

### SMALL FOOTPRINT

GT Force measures 31.5 inches wide and 66 inch deep. The small footprint allows more machines to be placed in a given area. It also makes arranging machines into work cell a cinch.



### CHIP MANAGEMENT

There are multiple nozzles on the table for air blow and coolant output. The coolant system flushes chips downward to be collected in the chip pan. The chip pan can easily slide away from the machine using wheels for clean up and coolant maintenance. Also available as an optional accessory is a coolant processor to automatically skim out tramp oil and sanitize coolant.

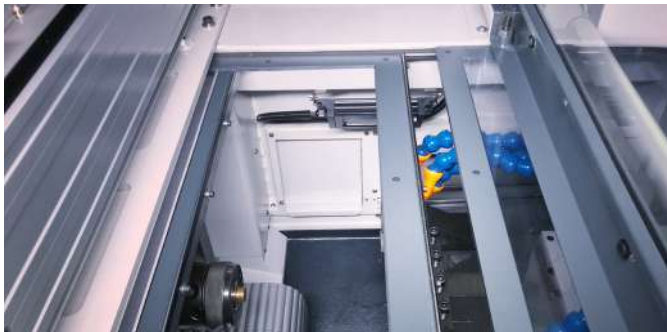

### AUTO DOOR

The machine is designed with an auto door for gantry robot to easily access the spindle for loading and unloading.

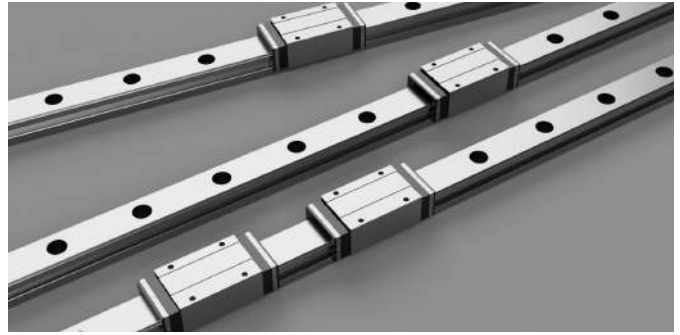

### LINEAR GUIDEWAYS

For GT Force, we selected world-class linear guideways that are durable, highly rigid and highly accurate. The X and Z axis rapid traverse speeds are 787 inches/min (20m/min).



### LIVE TOOLING

A wide range of live tools can be tailored to fit specific application requirements, including pneumatic spindle, direct drive electric spindle and belt drive spindle. Typically ER16 or ER20 collets are used.



### DOVETAIL TOOL CLAMPING

Dovetail tool clamping provides a rigid and repeatable connection between tool plate and tool blocks.

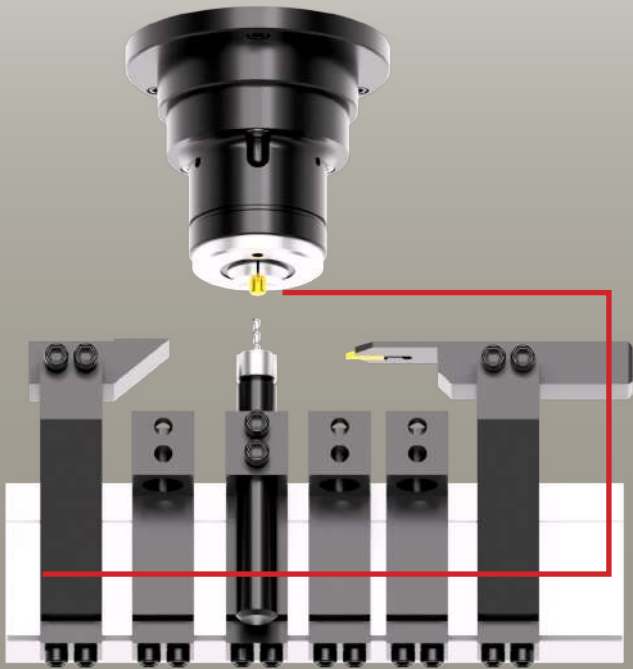

## GT FORCE-32 TOOLING AREA

Each tool block is 1.5" (38mm) wide. As many as 8 tools can be placed on the tool plate  
Tool plate width is 12.6 (320mm)

## TOOLING SYSTEM

Cubic can offer tooling package tailored to your application.

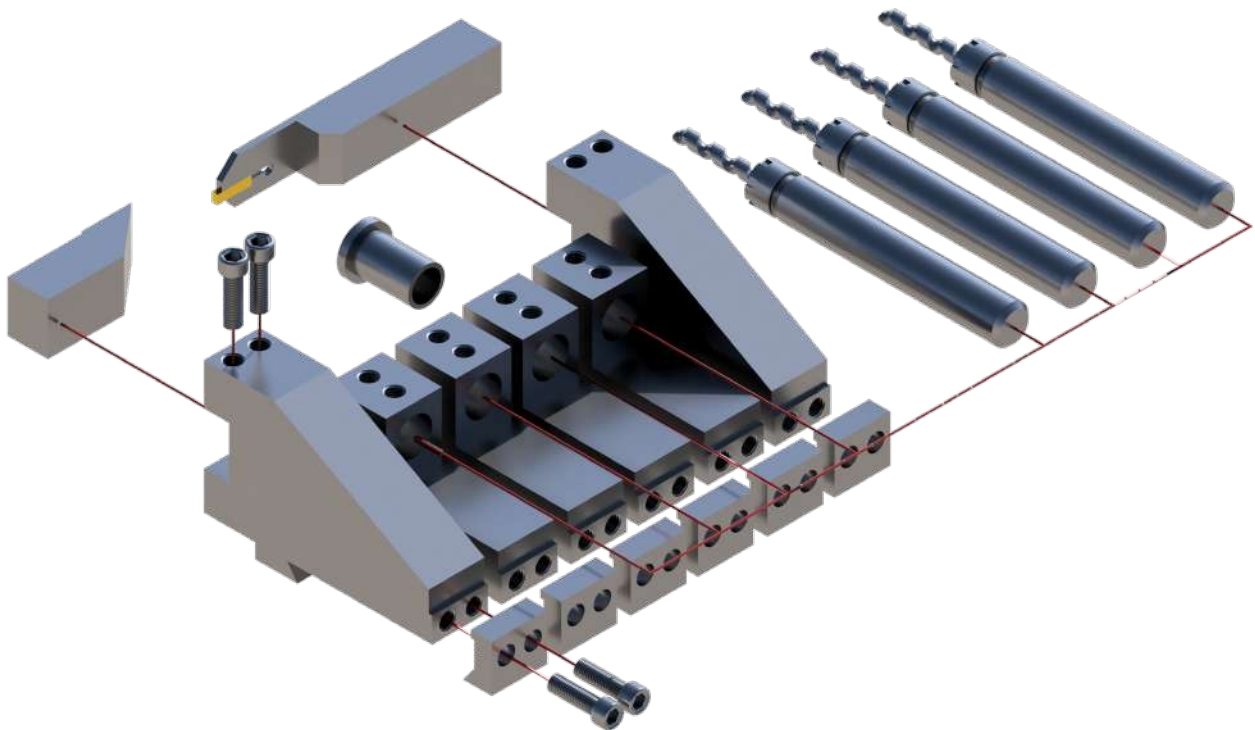

# SPECIFICATIONS

Model		GT Force-32	
<b>Machining capacity</b>	<b>Max turning diameter w/</b>		
	5c Collet	ø 1-1/16 in.	ø 27mm
	Dead-Length Collet Chuck	ø 1-3/16 in.	ø 30mm
	High Precision Air Chuck	ø 3 -5/32 in.	ø 80mm
	5" Hydraulic 3-Jaw Chuck	ø 3 -5/32 in.	ø 80mm
	Diaphragm Chuck	ø 3 -5/32 in.	ø 80mm
	Max Turning Length	2.36 in.	60 mm
<b>Spindle</b>	Through Hole	ø 1.77 in.	45 mm
	Draw Tube	ø 1.38 in.	35 mm
	Motor Drive	FANUC 7.5 HP	3.7 / 5.5 kw
	Max. Speed	6000 rpm	
<b>Axis</b>	Type	Linear ways	
	X-Axis Stroke	8.27 in.	210 mm
	Z-Axis Stroke	7.87 in.	200 mm
	X-Axis Servo Motor	1 HP	.75 kw
	Z-Axis Servo Motor	1 HP	.75 kw
	X/Z-Axis Rapid Speed	787.40 in. /min	20 m/min
<b>Tools</b>	Number Of Tools	6 ( 2 OD and 4 ID )	
	Turning Tool	0.63 in. (opt. .47" , .79")	16mm
	Drill Shank	ø 3/4 in.	20 mm
<b>General</b>	Hydraulic Unit	0.56 HP	0.4 kw
	Coolant Tank Capacity	29 gallons	110 L
	Coolant Pump	0.75 HP	0.56 kw
	Floor Space	L31.5xW66xH70.87 in.	L800 x W1680 x H1800 mm
	Weight	3792 lbs.	1720 kg
	Power Supply	AC / 3PH / 220V /	
Cnc Controller	FANUC Series Oi - TF		

Standard Accessories		Optional Accessories	
• 2 Turning tool holder	• Warning light	• 5C Collet nose	• Through spindle coolant
• 4 Drill holder	• LED work light	• 5" Hydraulic 3 jaw chuck	• Spindle ejection rod / part stopper
• ER 16 collet sleeves	• Tool box kit	• Coolant mist collector	• Chip conveyor
• Auto safety door	• Chip pan	• 30/70 Bar high pressure coolant pump	• Coolant maintenance system
• Air blow	• Coolant system	• Oil skimmer	• Also available with Glass scale



13401 Benson Ave., Chino, CA, 91710  
 Office: (909) 590-9995  
 Email: sales@cubicmachinery.com  
 Website: www.cubicmachinery.com

© 2018 Cubic Machinery, Inc. CUBIC, the CUBIC logo are trademarks and/or registered trademarks of Cubic Machinery, Inc. in the United States and other countries. All rights reserved. All company and/or product names are trademarks and/or registered trademarks of their respective manufacturers. Features, pricing, availability, and specifications are subject to change without notice.



**AMT Machine Tools LTD.**  
**Canadian Distributor**

73 Galaxy Blvd. Units 16 & 17, Rexdale, Ontario - M9W 5T4  
 Office: 416-675-7760 | Fax: 416-675-6988  
 www.AMTmachine.com | sales@amtmachine.com