

 **CUBIC**
MACHINERY



GT MAX

Series

Multi-slide CNC Lathe

GT MAX Series

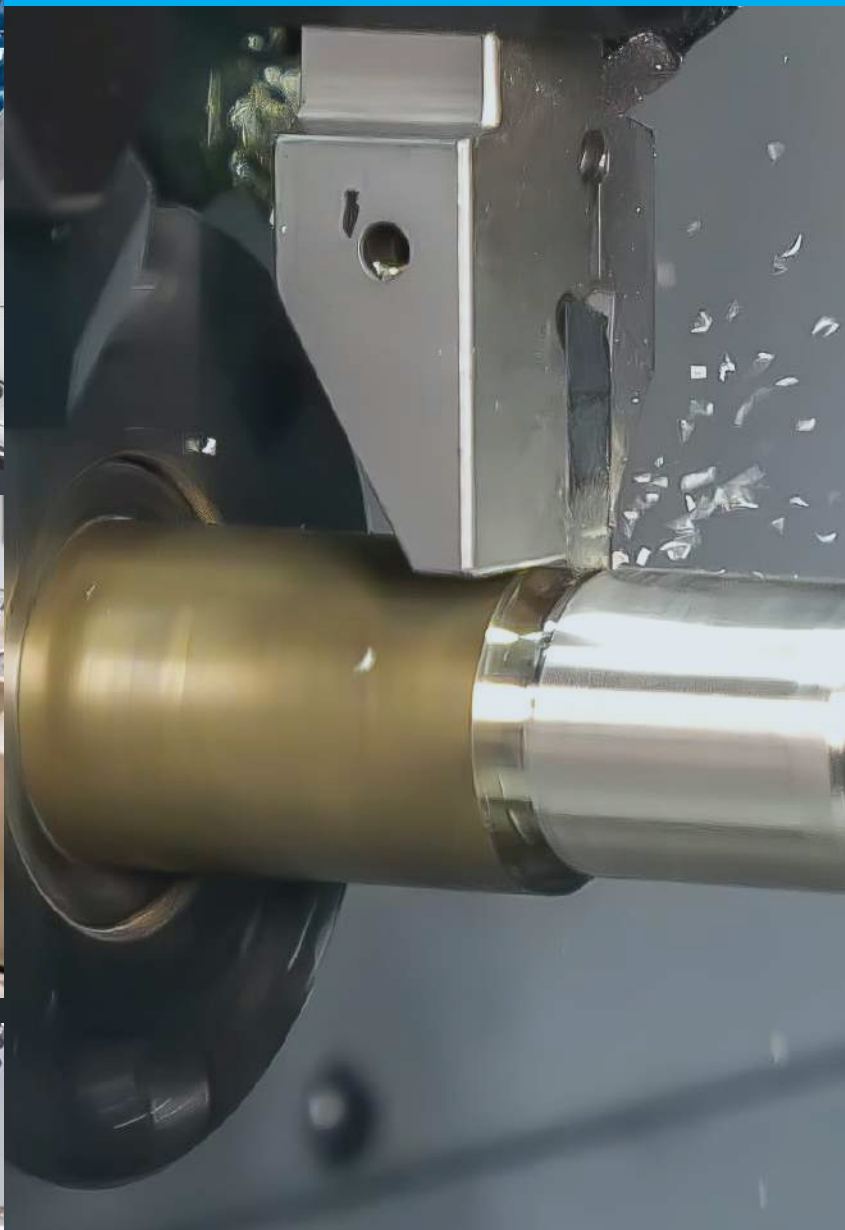



MULTI-SLIDE CNC LATHE is now on the market!

One can completely replace the cam-type automatic lathes.

GT Max series combine the speed of cam-driven automatic lathes with ease of setup of modern

At Cubic, power, quality and economy are not mutually exclusive. GT Max is certain to help you produce more precision parts per hour than any other lathe in the market.

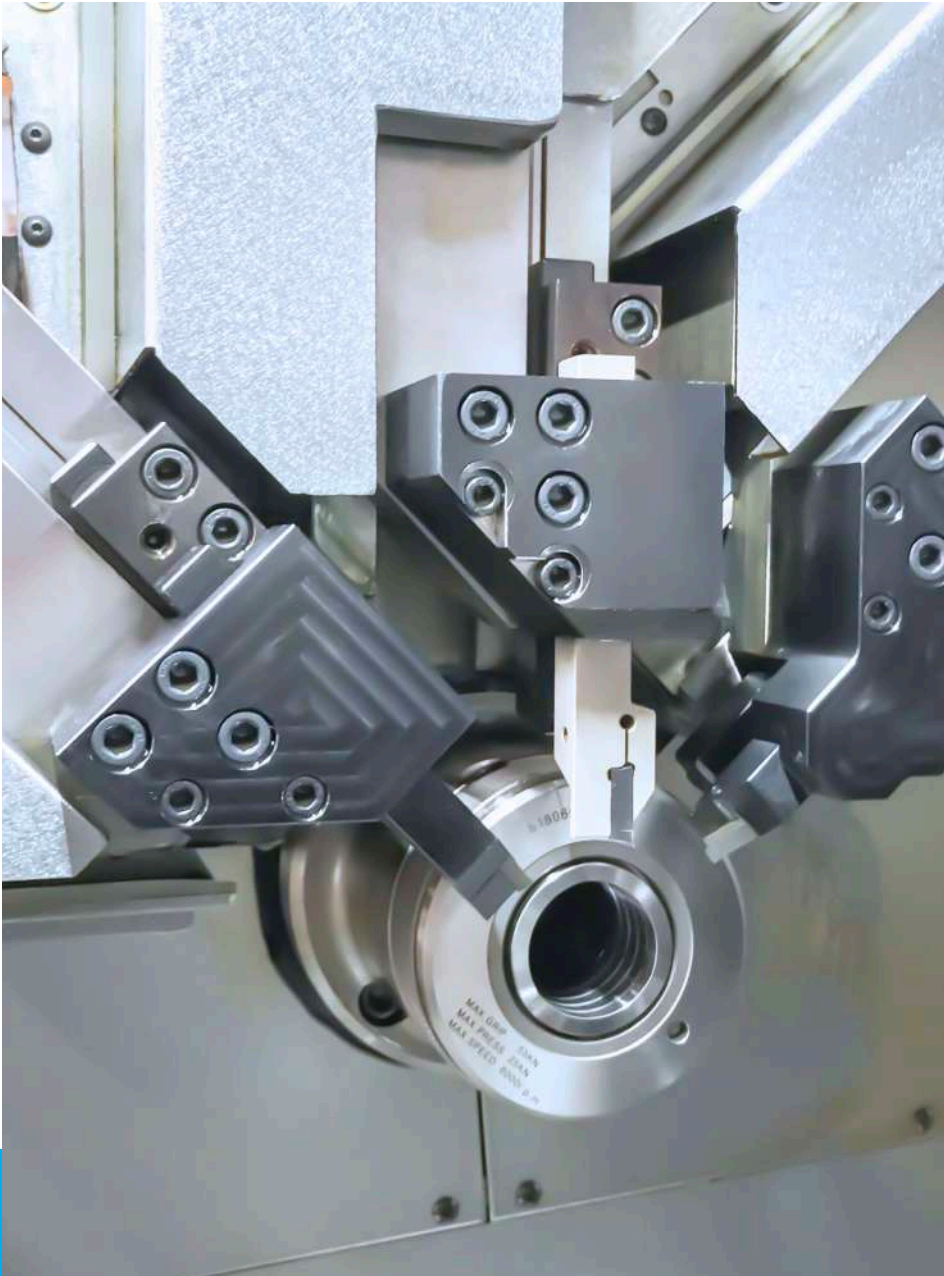

- Up to 3 simultaneous cuts from 3 slides, each with 2 tool positions.
- Gang tool slide with up to 4 boring tool holders. Optional 8-position servo turret is also available.
- Front and back spindle each has independent tool slide.
- GT Max 42 D available with full X, Z movement on back spindle.



GT-Max 42D



GT-Max 25

Dimensions

GT Max 42D

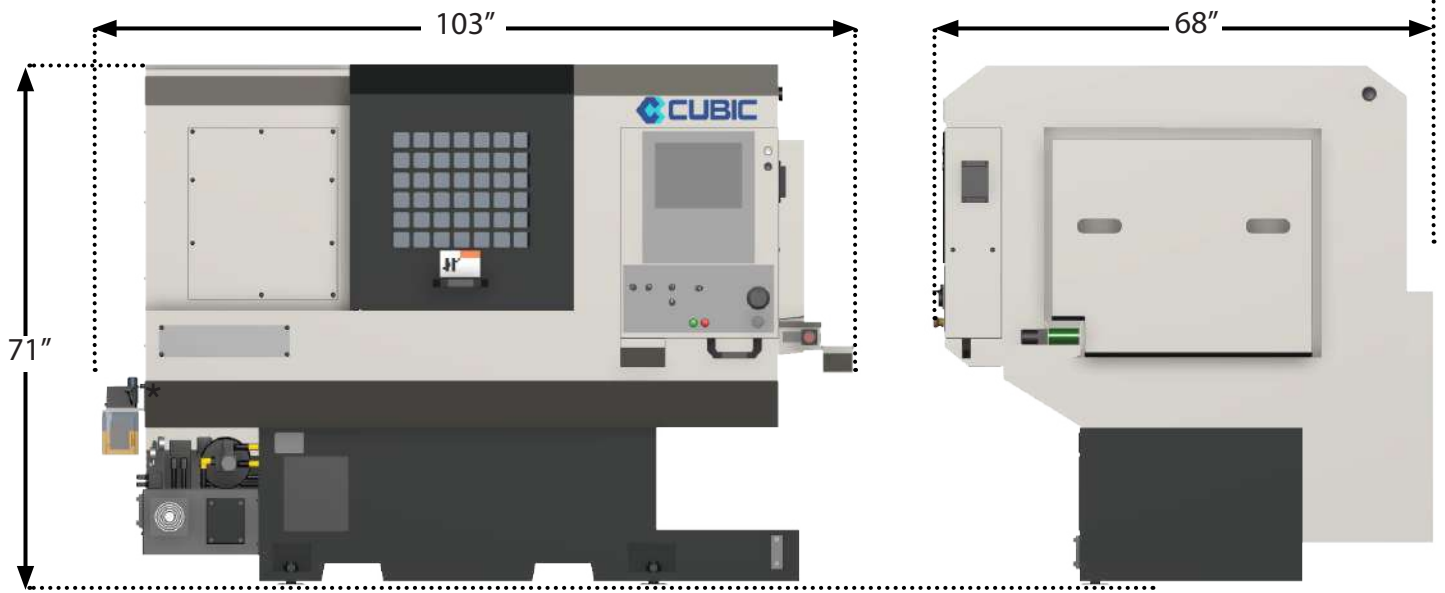

GT Max 25

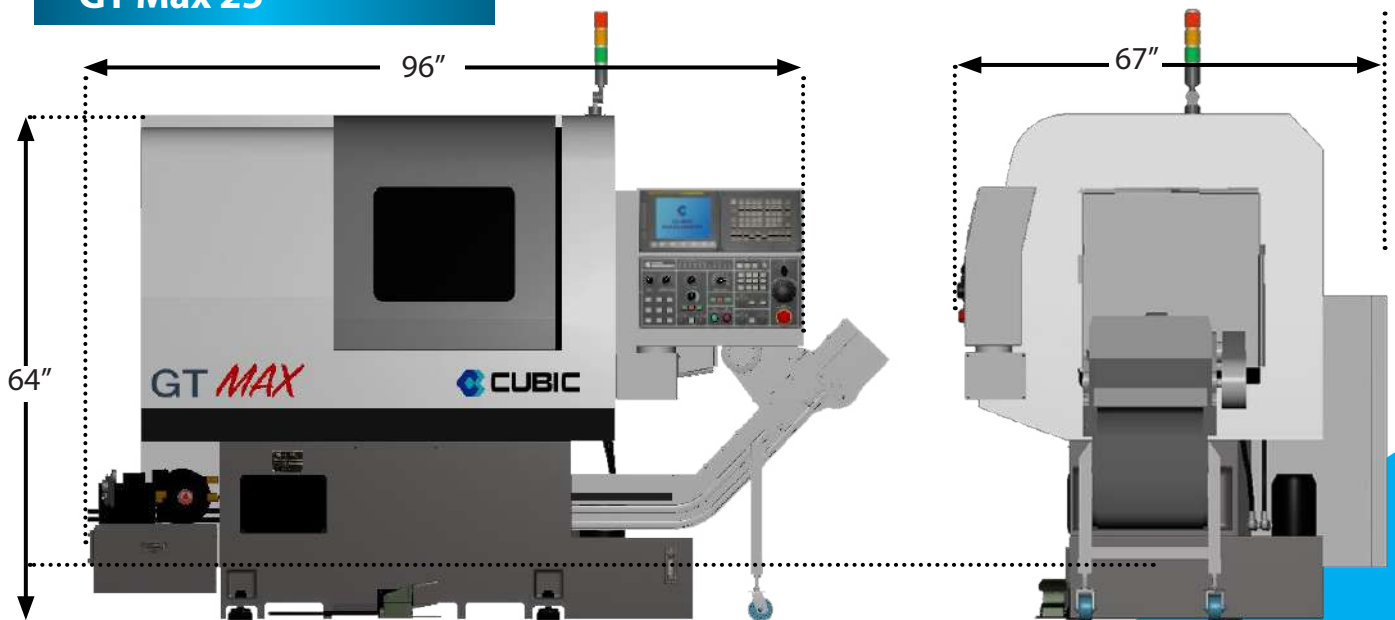

Z2,Z3,Z4=100mm

X2,X3,X4=50mm

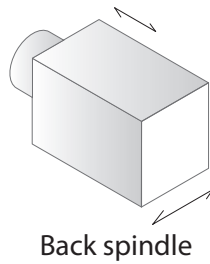
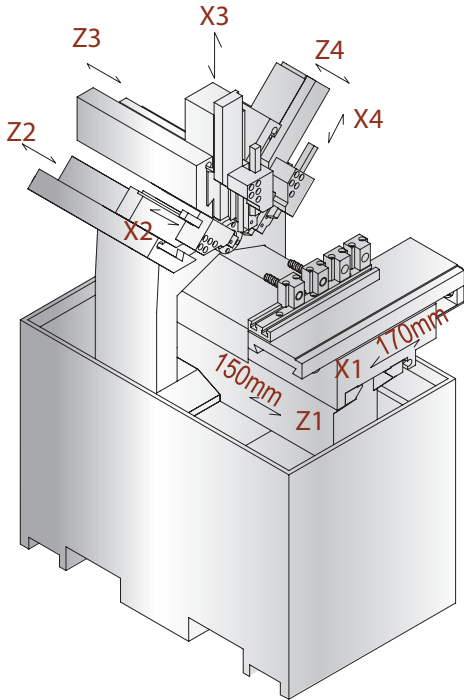

GT Max 42D

Z2,Z3,Z4=60mm

X2,X3,X4=70mm

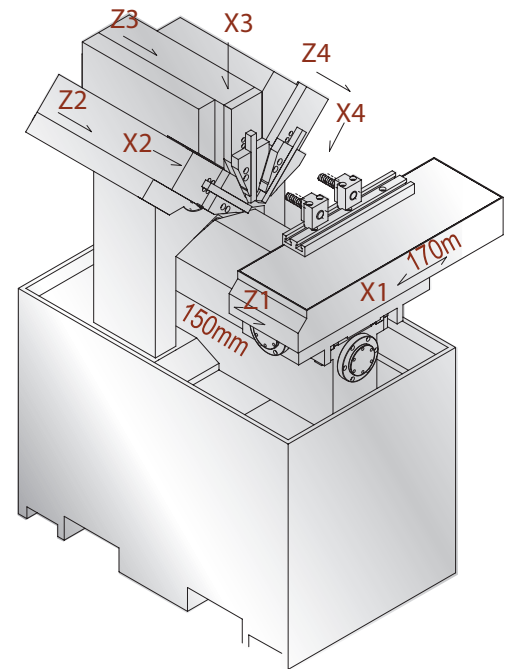

GT Max 25

SPECIFICATIONS

	GT MAX 25		GT MAX 42D	
Bar capacity	25 mm	1.02 inch	42 mm	1.02 inch
Max cutting length	108 mm	4.25 inch	108 mm	4.25 inch
Max cross travel (X-axis)	170 mm	6.69 inch	170 mm	6.69 inch
Max longitudinal travel (Z-axis)	150 mm	5.91 inch	150 mm	5.91 inch
Collet type	DIN 6343 161E	DIN 6343 161E	DIN 6343 171E	DIN 6343 171E
Spindle motor	3.7 kw	5 hp	3.7 kw	5 hp
Spindle speed range	100 - 5000n rpm	100 - 5000 rpm	100 - 5000 rpm	100 - 5000 rpm
Rapid traverse speed (X, Z-axis)	15 m/min	591 ipm	15 m/min	591 ipm
Min input unit	0.001 mm	0.0001 inch	0.001 mm	0.0001 inch
Cutting tool size	16x16 mm	0.63 x 0.63 inch	16x16 mm	0.63 x 0.63 inch
Max boring bar	20 mm	0.79 inch	20 mm	0.79 inch
X1/Z1/Z2/A1/Z3-axis motors	0.75 kw	1 hp	0.75 kw	1 hp
X2/Y2/X2-axis motors	0.37 kw	0.5 hp	0.37 kw	0.5 hp
Number of cross slide tools	6 pcs	6 pcs	6 pcs	6 pcs
Coolant pump motor	186 watt	1/4 hp	186 watt	1/4 hp
Machine dimensions (LxWxH)	1665x1362x1530 mm	65 x 53 x 60 inch	1665x1362x1530 mm	65 x 53 x 60 inch
Net weight	1220 kg	2684 lb	1320 kg	2904 lb

STANDARD ACCESSORIES

ITEMS	Q'TY	GT Max 25	GT Max 42D
Collet Nose	1 pc	●	●
Work light	1 pc	●	●
Tool and toolbox	1 pc	●	●
Coolant system	1 pc	●	●
Leveling blocks	4 pcs	●	●
Boring tool holder	4 pcs	●	●
Tool holder bushings 6/8/10/12/16	2 pcs each	●	●



13401 Benson Ave., Chino, CA, 91710
 Office: (909) 590-9995
 Email: sales@cubicmachinery.com
 Website: www.cubicmachinery.com

© 2019 Cubic Machinery, Inc. CUBIC, the CUBIC logo are trademarks and/or registered trademarks of Cubic Machinery, Inc. in the United States and other countries. All rights reserved. All company and/or product names are trademarks and/or registered trademarks of their respective manufacturers. Features, pricing, availability, and specifications are subject to change without notice.



AMT Machine Tools LTD.
Canadian Distributor

73 Galaxy Blvd. Units 16 & 17, Rexdale, Ontario - M9W 5T4
 Office: 416-675-7760 | Fax: 416-675-6988
 www.AMTmachine.com | sales@amtmachine.com