

SWISS TYPE AUTOMATIC LATHE equipped with star motion control system 

SR-38 type B

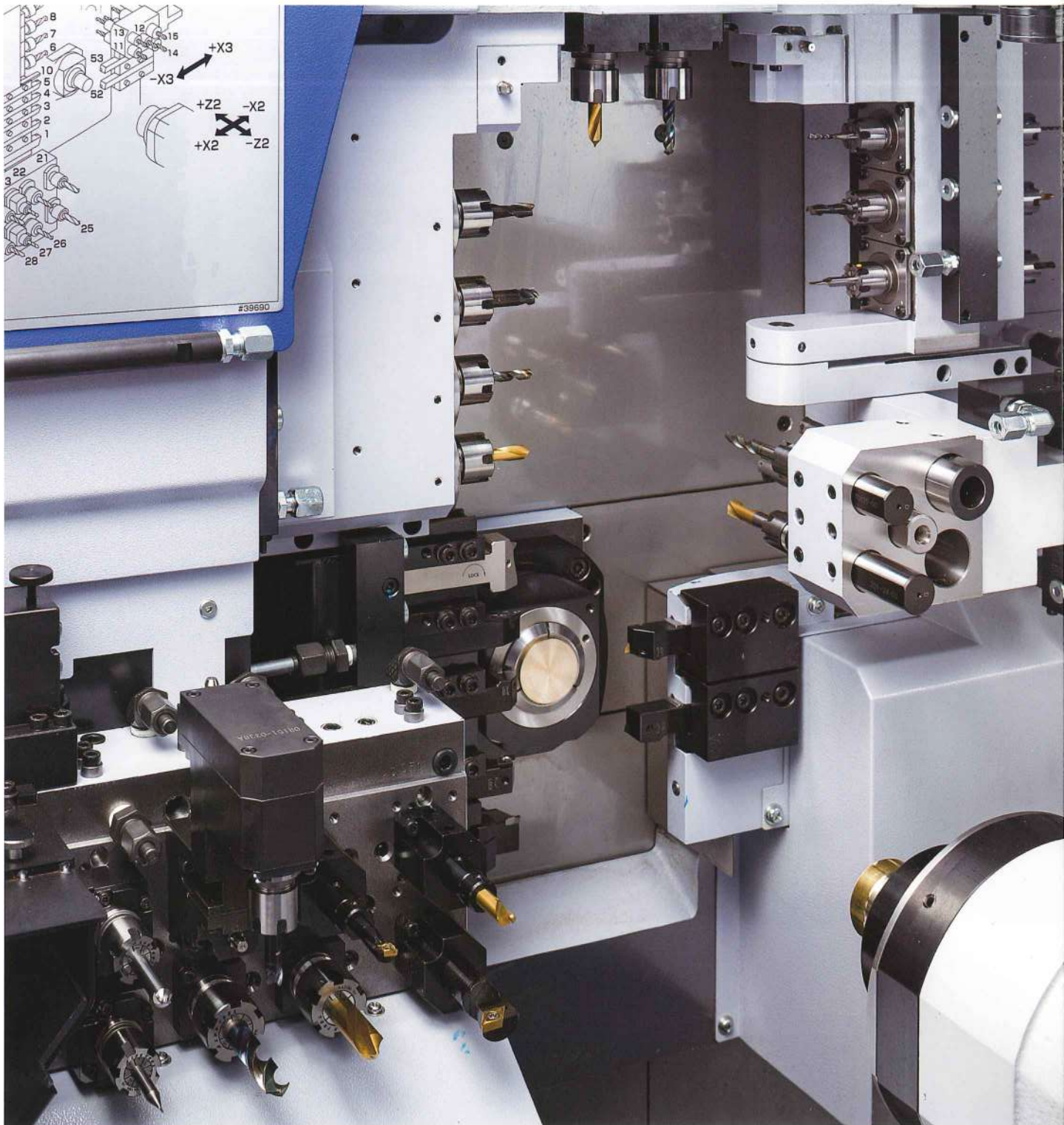

The machine configuration is designed to further assist the complex components in the large-diameter sectors.





production of medium

This Quick and versatile multi axis machine offers many functions like balance turning, a fully programmable B axis together with an independent 8-spindle backworking unit for maximum overlapping capability.

This modern machine is designed for large-diameter workpiece production and further enhances the SR series of machines. The rigid platen type tool post incorporates a "uniform load crops guide structure" which minimizes momentary load applied to the LM guide bearings and therefore improves tool post rigidity. The balance turning function is made by means of the simultaneously controlled X1/X3 axes, the 3 spindle Counterface B axis unit enables angular drilling on both main & sub spindles and the Y axis-controlled 8-spindle backworking unit, further enhances the degree of complexity of part that can be produced on this machine. The cartridge type power tool positions provide the flexibility to mount many different driven tools like Thread whirling, polygon milling and slotting units

For customers wishing to produce even more complex components with high accuracy and high production requirements the SR-38B makes this possible.

SR-38 type B

CNC SWISS TYPE AUTOMATIC LATHE equipped with Star motion control system

Control method : CNC control by Star motion control system

Machine composition :

Main spindle

Sub spindle

Gantry-type tool post (B-axis control power-driven tool unit)

8-spindle back working unit with Y-axis control function

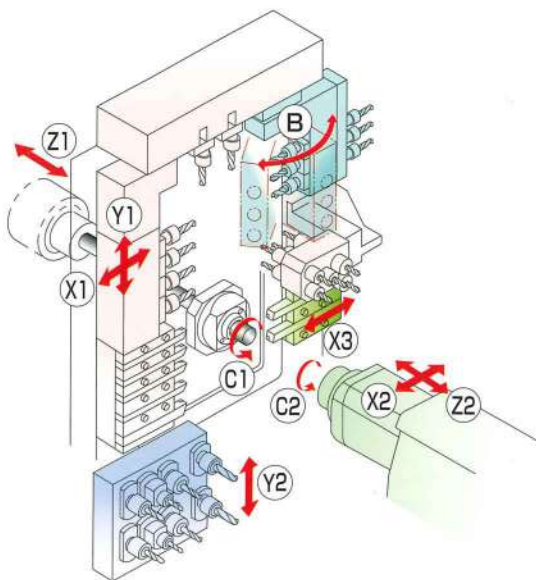

TOOLING SYSTEM

■ Tool holder	Turning tool	7 tools (5 tools on the front / 2 tools on the rear)
■ 5-spindle sleeve holder	Front-end stationary tool	5 tools
	Rear-end stationary tool	5 tools
■ Power-driven tool	Cross machining tool only	4 tools
	Cartridge type	2Pos
	Power-driven tool unit	1 Pos (front 3 tools / rear 3 tools)
■ Back 8-spindle unit	Rear-end stationary tool	Max. 8 tools
	Rear-end power-driven tool	Max. 8 tools

In pursuit of up-graded function, production and accuracy from every angle

High Functionality & Enhanced Machining Capability

① X3 controlled axis added

A tool holder with X3-axis control function is provided on the rear side of the platen-type tool post.

② Angle adjustable power tool unit

Equipped with programmable 3-spindle counter facing-type unit with a B-axis. Capable of oblique machining such as oblique holes on both front and back sides.

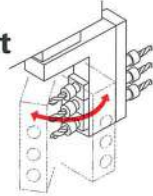

③ Two cartridge positions

Various power tool units can be mounted at the cartridge positions for slitting, polygon processing, etc. to realize a variety of tooling layouts suited to workpieces to machine.

④ G. B & N.G.B change-over mechanism

The guide bush type and the non-guide bush type can be changed over according to the total length of workpieces to achieve optimum machining.

The display shows every step to follow through a blinking lamp to support a smooth change-over operation.

By proceeding with the job in accordance with the procedures displayed on the operation panel, switching from the guide bush type to non-guide bush type is easily accomplished.



Striving for High Productivity (& Reduced Machining Time)

① Balance cut mechanism

Balance cutting using the X1/X3 simultaneous control reduces the machining time especially in hard to machine materials.

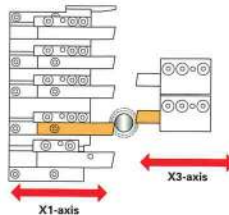

② Flexible overlap machining

The 8-spindle backworking unit with Y-axis control ensures efficient process splitting between front and back workings and flexible overlap machining.

③ Star motion control system

Type B is equipped with unique Star motion control system to minimize the control system change-over time, tool change time and other non-cutting time.

Improved productivity is emphasized from the view point of both the mechanical and control sides.

Significant Reduction of Non-Cutting Time

Star Motion Control System

This control system converts the NC program through "optimization" and finishes processing related to switching of the control system in order to enable "tool selection for the next process and approach during cutting" and "tool disengagement and next cutting at the same time".

By this control method, the non-cutting time, which is considered to be a disadvantage for NC-controlled machines, is largely reduced and contributes to improved productivity. - Furthermore, this control system moves each axis while taking the shortest way, utilizing the previous cutting process time to minimize excessive vibration caused by axis feed and contributes to the maintenance of stable machining accuracy.

① Concept of cutting time reduction

Conventional CNC-controlled machining



Machining through Star motion control system



By the program optimization, the time required for the processes of [Disengagement], [Next tool selection] and [Approach] can be minimized to reduce the non-cutting time.



High Rigidity & High Accuracy Achieved

① Platen type tool post employing uniform load cross guide structure

The platen type tool post incorporates a tool post with 8 linear bearings arranged uniformly around the point (= guide bush) where a cutting load is applied. By distributing the cutting load to 8 guide bearings at all times, the moment load applied to each guide bearing is minimized and rigidity of the tool post is improved.

Thanks to high dynamic stability, continuous operation is possible for a long time with stable accuracy and longer service life of the linear guide bearing is ensured.

X,Y AXIS POSITION ①

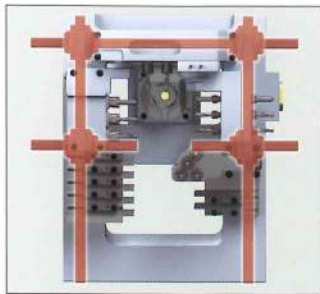

X,Y AXIS POSITION ②

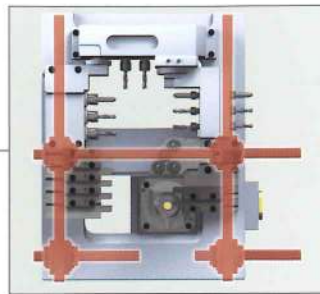

X,Y AXIS POSITION ③

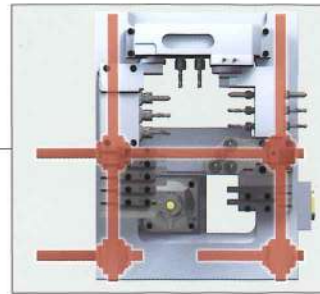

Uniform Load Cross Guide Structure

High rigidity tool post

The moment load is applied to eight bearings uniformly at all times even when the X/Y axis moves because the guide bush is positioned in the guide bearing.
(See figures ①, ② and ③)

② Spindle sleeve slide guideway structure (N.G.B type)

The machine is so constructed to guide the Z axis along the spindle sleeve outer periphery of the headstock. Machining load is supported close to the cutting point so that the headstock rigidity is improved and continuous machining with stable accuracy is ensured.

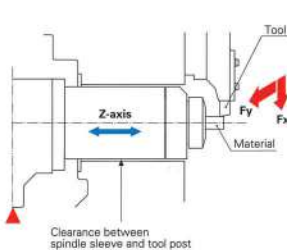

↑ For ordinary non-guide bush type

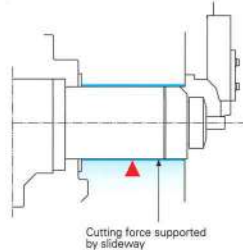

↑ For SR-38 non-guide bush type

③ Introduction of built-in spindle

Introduction of the built-in type spindle and sub spindle enhances indexing accuracy.

④ Hydraulic spindle chucking unit

The spindle chucking unit uses a hydraulic rotation cylinder to achieve stable chucking capability regardless of variations in diameter of large-diameter workpieces.

⑤ Higher rigidity of each section

The machine is carefully designed for higher rigidity by employing a slide guideway of the rear side X3 tool post, both end support structure of swivel type 3-spindle unit, etc.

04

Improved Operability and Productivity

① Movable operation panel

The movable operation panel allows operation at the best position for operation.

② Swing-up door

The swing-up door allows enlarged opening of the headstock chamber and the cutting chamber, and ensured a large work space.

STAR Environmental Standards Conformity models



Star Micronics defines machine tools conforming to the following environmental standards as "Star Environmentally Compatible Machines".

Adaptation Criterion

- Powder-coated external cover
- RoHS compliance part ratio: 99% or more

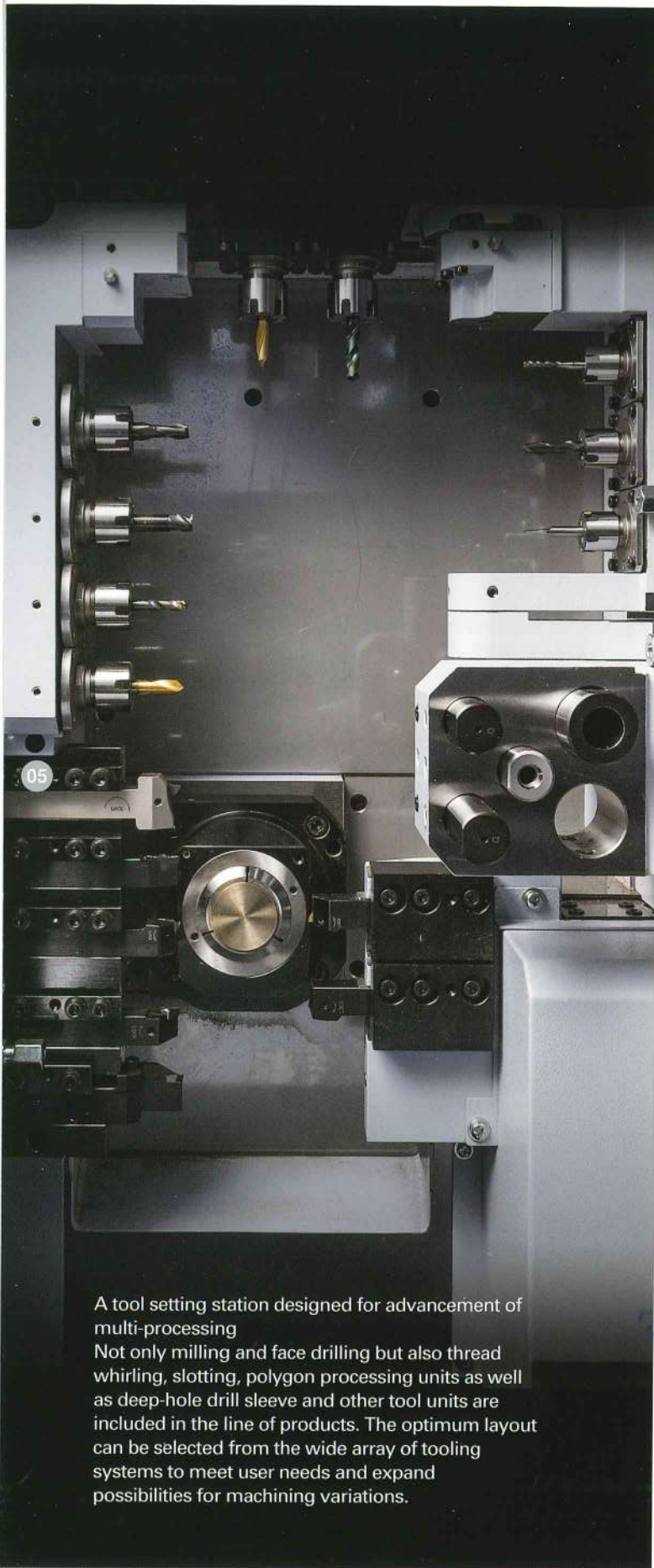

A tool setting station designed for advancement of multi-processing
 Not only milling and face drilling but also thread whirling, slotting, polygon processing units as well as deep-hole drill sleeve and other tool units are included in the line of products. The optimum layout can be selected from the wide array of tooling systems to meet user needs and expand possibilities for machining variations.

TOOLING SYSTEM

Gantry-Type Tool Post

Basic type

Cartridge (2 pos.)

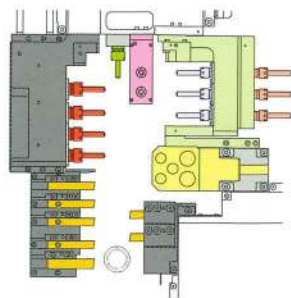

VARIATION 02
 Cartridge (2 pos.)



2-spindle front drill unit

■ Milling unit
 ■ 2-spindle front drill unit

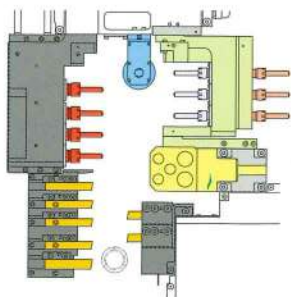

VARIATION 04
 Cartridge (1 pos.)



■ Polygon machining unit

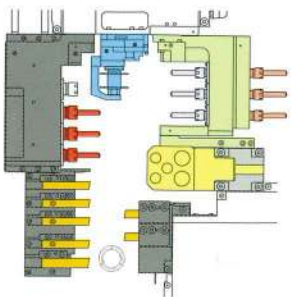

VARIATION 06
 Cartridge (1 pos.)



■ Slotting unit

A Variety of Tooling Layouts

8-spindle back working unit with Y-axis control function

TOOLING SYSTEM

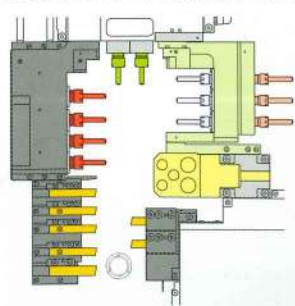

Milling unit ER20

VARIATION 01
Cartridge (2 pos.)

■ Milling unit

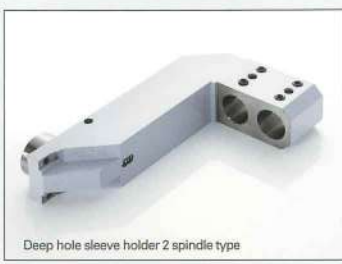
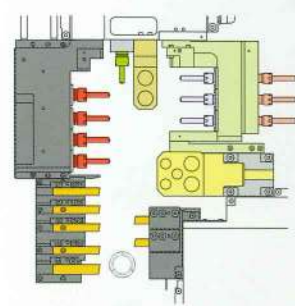

Deep hole sleeve holder 2 spindle type

VARIATION 03
Cartridge (2 pos.)

■ Milling unit
■ Deep hole sleeve holder 2 spindle type

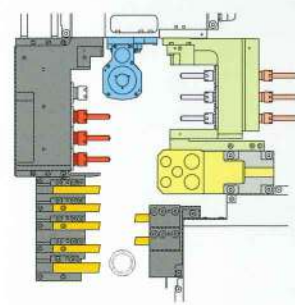

■ Thread whirling unit

VARIATION 05
Cartridge (1 pos.)

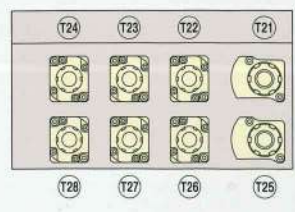

- Max. 8 power tools mountable
- Various power tool units available
- Compliant with coolant-through tools

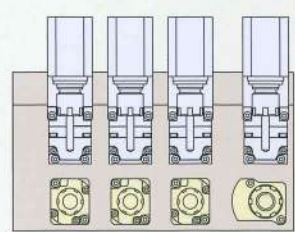

Cross drill unit

case01

Mounting of cross drill unit

- Mounting at T21 through 24 positions
- Continuous mounting at adjoining positions

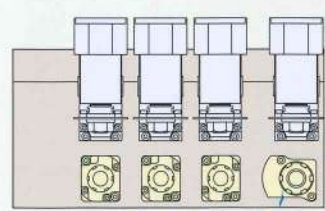

Slotting unit

case02

Mounting of slotting unit

- Mounting at T21 through 24 positions
- Continuous mounting at adjoining positions

Coolant-through drill sleeve (on the back side)



Drill sleeve ER16



Drill sleeve ER20



Drill sleeve ER25

A wide range of machining variations

Front working variation

VARIATION 01

Balance cutting
X3 axis controlled balance cut

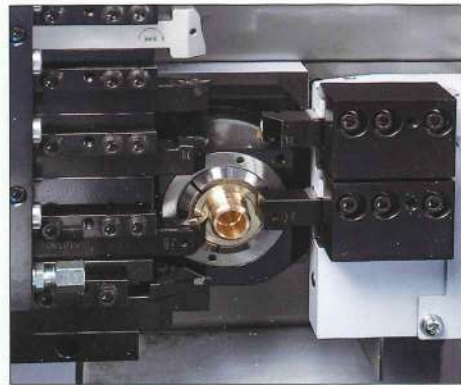
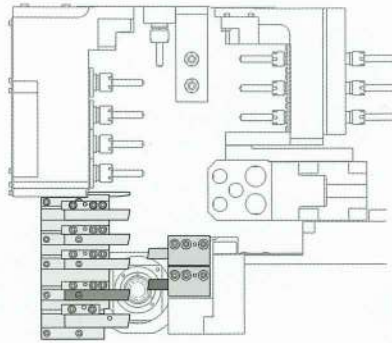

07

VARIATION 02

B axis swing
B axis power tool swivel control

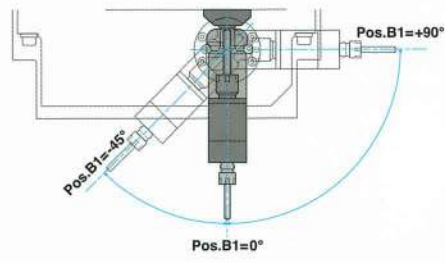

VARIATION 03

Diagonal machining
Diagonal machining using power-driven tool with B axis/angle adjustable power-driven tool

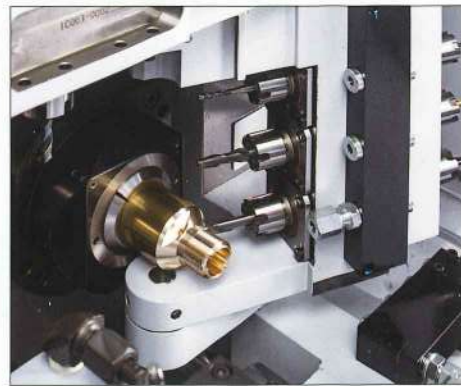
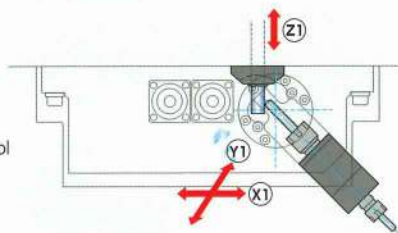

Rear working variation

VARIATION 01

Cross drilling

Back cross drilling

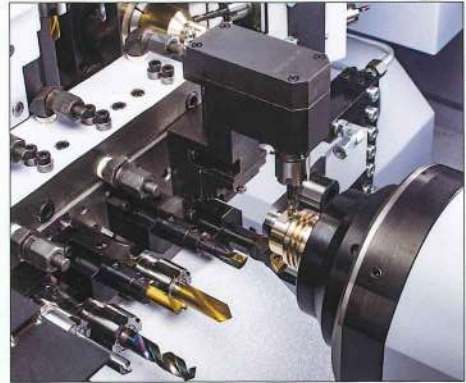
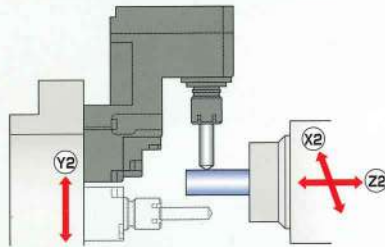

VARIATION 02

Diagonal machining

Back diagonal machining using power-driven tool with B axis/angle adjustable power-driven tool

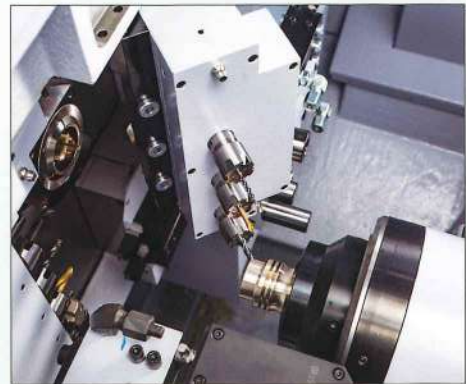
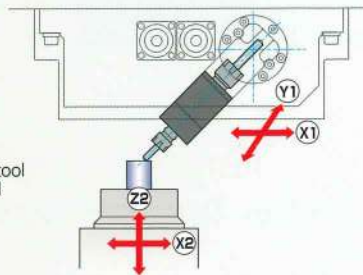

The NC System Continues to Evolve to be Friendly to Every Operator.

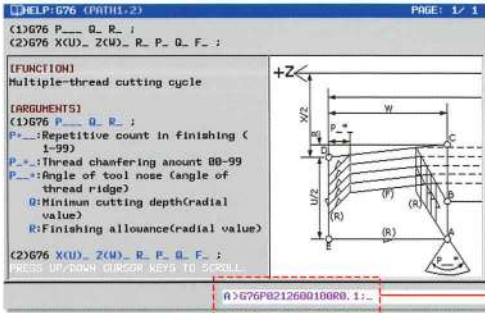

Convenient command help screen !



An image is displayed on the command help screen to check detailed command so that the help contents can be understood by intuition. Code inputting to insert into the currently edited program is also possible with the help screen displayed.

Convenient Alarm Help Function

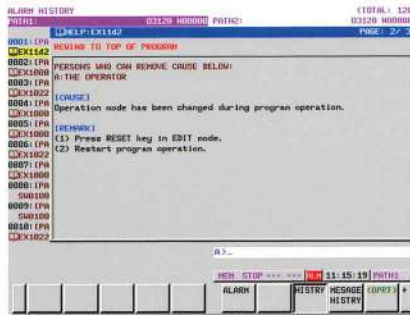
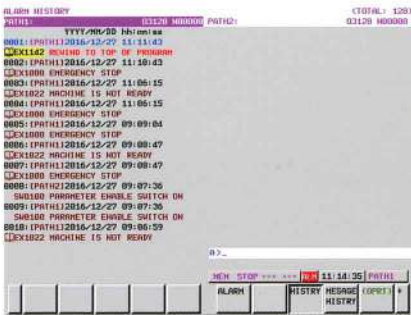

The Star original alarm help screen is added. When [Help] is selected from the bookmark, the pop-up screen is displayed and alarm details can be checked even if there is no instruction manual. Together with the troubleshooting information, a list of personnel who can remove the alarm is also displayed to clear the problem smoothly.

09

Multi-System Program Control

Program input/output between the NC unit and the memory card can be done by a single operation for all systems. Programs for all systems can be compiled in one file (with extension ".AP"). Copy, delete and new creation can also be done by one operation.

*Files with an extension ".PA" are supported by Star program control software "PU-Jr." Non-compliant models will gradually be changed to be compliant in the future.

MULTI-PATH PROGRAM MANAGER		
MULTI-PATH	USED PAGE FREE PAGE	MEMORY CARD
00006		00001.PA
01000		00058.PA
01006		00150.P2
01007		01003.PA
01111		01234.PA
01212		01658.PA
01234		02000.P1
02222		02258.PA
02333		03357.PA
03090		03358.PA
03093		03359.P2
03111		05875.P1
		TEST.PA

FANUC Series 32i-MODEL B

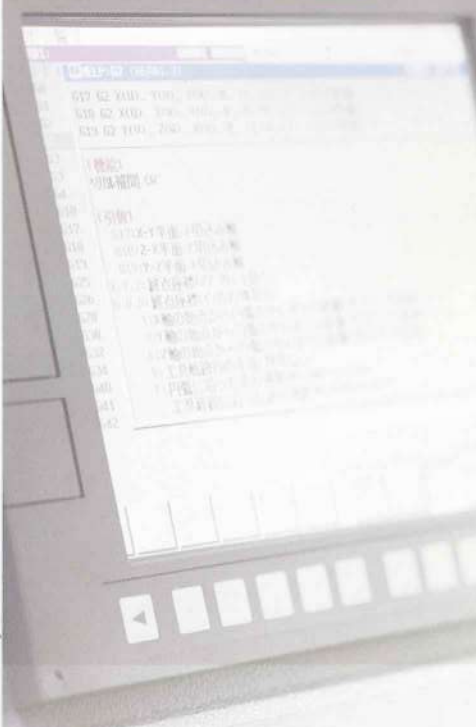

Convenient count-up prediction function !

Tool life can be managed for each tool number. The count arrival forecast function also gives warning through the count arrival forecast time display, tool counter red display and operator message (No. 2047) display if any tool life is expected to expire within 24 hours. With this function, the operator can prepare a replacement tool before the machine stops and reduce the non-running time.

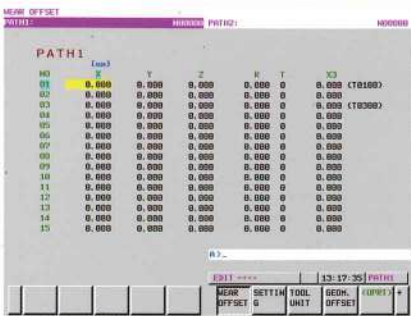

Convenient Wear Offset Screen

The tool wear offset number which is used is displayed on the right end of the screen during execution of the machining program. This enables to check the applicable offset number easily when changing the offset value.

Simple Spindle Phase Synchronization Function

The spindle phase synchronization for machining profile bars required complicated procedures with conventional models, but this procedure is partially automated by this function. Simple button operation following the instructions displayed on the screen enables smooth adjustment.

Convenient maintenance timer & counter !

The number of maintenance timers is increased to 10 (Note*) to enable character input to the reference column. Besides the maintenance timer, a maintenance counter is also added to control the time and count.



Note *
This number is 5 for SR-20RIV.

Convenient tool selection function !

A tool selected on the screen can be positioned with the machining chamber door opened. Simultaneous operation, using two buttons, is also possible. In order to emphasize safety during operation. Positioning not only in the axial (X) direction but also center height (Y) direction is also possible.

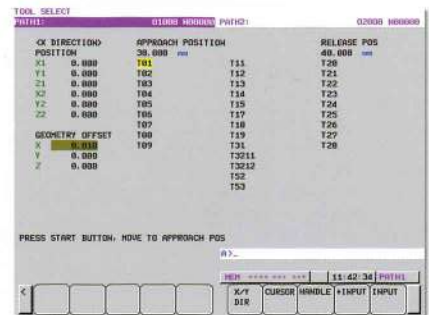

Convenient Undo Function

In case of the wrong input, simply press the [Undo] key to revert back to the previous value.

*The undo function is usable on the wear offset screen and geometry offset screen.

Convenient insulation deterioration detection function!

Insulation deterioration of servo motor, spindle motor and their power cables is automatically detected. Therefore, potential trouble can be located for maintenance and replacement of parts before the machine stops. In addition to insulation deterioration, a power fault, FSSB cable deterioration and various detector faults can also be detected.

Standard Machine Specifications

OP : Option

Item	Specifications	
Max. machining diameter	φ38mm(1-1/2in)	
Max. headstock stroke	Standard	320mm(12-19/32in)
	With R.M.G.B. unit	288mm(11/32in) : OP
	Non-guide bush type	Bar diameter×2.5(Max.95mm)/(Max.3-47/64in) : OP
Tool	5 tools on the front(stationary type)+2 tools on the rear(X3 axis control)	
5-Spindle sleeve holder	Number of tools	Front 5 tools
		Rear 5 tools
	Max. drilling capability	φ23mm(29/32in)
	Max. tapping capability	M16×P2.0
Power driven attachment	Number of tools	Cross milling : 4 tools Cartridge type : At 2 position
	Number of tools	B-axis controlled power-driven tool unit : At 1 position (Front 3 tools+Rear 3 tools)
	Max. drilling capability	φ10mm(25/64in)
	Max. tapping capability	M8×P1.25
	Spindle speed	Max.6,000min ⁻¹
	Drive motor	2.2kW(continuous) / 3.0kW(5min./30%ED)
	Rapid feed rate	36m/min(X1,Y1,Z1,X2,Z2), 24m/min(Y2,X3)
Main spindle indexing angle	C-axis control	
Main spindle speed	Max.7,000min ⁻¹	
Main spindle motor	7.5kW(continuous) / 11kW(10min./25%ED)	
Coolant tank capability	253 ℓ (359 ℓ : OP)	
Dimensions (WxDxH)	2,740×1,315×2,120mm	
Weight	4,300kg	
Power consumption	16.9 kVA	

Backworking Attachment Specifications

Item	Specifications	
Max. chucking diameter	φ38mm(1-1/2in)	
Max. length for front ejection	150mm(5-7/8in)	
Max. parts projection length	70mm(2-3/4in)	
Back 8-Spindle unit	Number of tools	8 tools
	Max. drilling capability	Stationary tool φ14mm(35/64in)
	Power driven tool	8 mm(5/16in)
	Max. tapping capability	Stationary tool M12×P1.75 Power driven tool M6×P1.0
Power-driven att. spindle speed	Max.6,000min ⁻¹	
Power-driven att. drive motor	1.0kW(continuous) / 1.2kW(5min./30%ED)	
Sub spindle indexing angle	C-axis control	
Sub spindle speed	Max.7,000min ⁻¹	
Sub spindle motor	3.7kW(continuous)/5.5kW(10min./40%ED)	

External Dimensions

Unit : mm(ft)

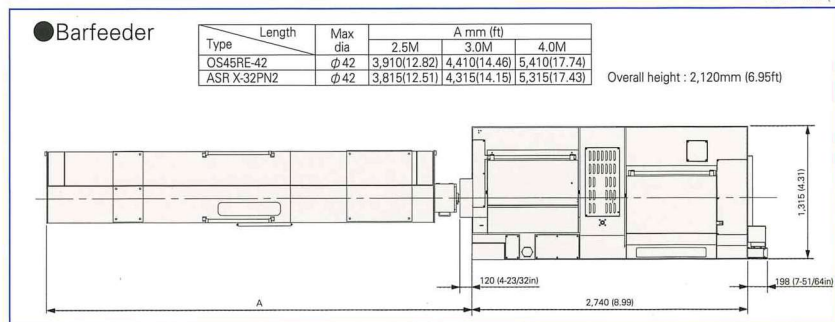

※Design features, specifications and technical execution are subject to change without prior notice.

※This product is an export control item subject to the foreign exchange and foreign trade laws. Thus, before exporting this product, or taking it overseas, contact your STAR MICRONICS dealer.

STAR MICRONICS CO., LTD.

Machine Tools Division

1500-34 Kitanoya, Misawa, Kikugawa, Shizuoka, 439-0023 Japan
TEL.+81-537-36-5594 FAX.+81-537-36-5607

<https://star-m.jp/eng/>

Star CNC Machine Tool Corporation
123 Powerhouse Road, Roslyn Heights, NY 11577, U.S.A.
TEL.+1-516-484-0500 FAX.+1-516-484-5820

Star Micronics GB Limited
Unit 1 Riverlands Business Park Raynesway DERBY DE21 7BZ
TEL.+44-1332-86-44-55 FAX.+44-1332-86-40-05

Star Micronics GmbH
Robert-Grob-Str.1, D-75305 Neuenbürg, Germany
TEL.+49-7082-7920-0 FAX.+49-7082-7920-20

Star Micronics AG
Lautstrasse3, CH-8112 Otelfingen, Switzerland
TEL.+41-43-411-60-60 FAX.+41-43-411-60-86

Star Machine Tool France
90 Allée de Glaisy, ZI, 74300 Thyez Haute Savoie, France
TEL.+33-450-96-05-97 FAX.+33-450-96-91-54

Shanghai Xingang Machinery Co., Ltd.
2F, 229 Fute Rd.N. The China (Shanghai) Pilot Free Trade Zone
TEL.+86-21-5868-2100 FAX.+86-21-5868-2101

Star Micronics (Thailand) Co., Ltd.
289/23 M.13 Soi Kingkaew 25/1, Kingkaew Rd., T.Rachathewa A, Bangplee Samutprakarn 10540, Thailand
TEL.+66-2-186-8945-47 FAX.+66-2-183-7845

9001 ISO 14001
CERTIFIED

2022.12_Ver1.2_4



AMT Machine Tools LTD.
Canadian Distributor

73 Galaxy Blvd. Units 16 & 17, Rexdale, Ontario - M9W 5T4
Office: 416-675-7760 | Fax: 416-675-6988
www.AMTmachine.com | sales@amtmachine.com

Standard Accessories and Functions

1. CNC unit FANUC 31i-B5
2. Operation panel 10.4-inch color LCD display
3. Pneumatic unit
4. Hydraulic unit
5. Automatic centralized lubrication unit
6. Coolant level detector
7. Door interlock system
8. Broken cutoff tool detector
9. Drive unit for revolving guide bush
10. Revolving guide bush unit
11. Air purge unit for revolving guide bush
12. Main/Sub collet
13. C-axis control (Main/Sub)
14. Spindle clamp unit (main/sub)
15. 5-station tool holder □16/20mm
16. 2 tool holder □16mm
17. 5-spindle sleeve holder
18. Cross milling tool unit (4-tool type)
19. 3-spindle opposing unit with B axis control
20. Air purge unit for sub spindle
21. 8-spindle back working unit with Y axis control function
22. 8-spindle back working unit power tool drive
23. Parts conveyer
24. Work light
25. Leakage breaker

Optional Accessories and Functions

1. Coolant flow detector
2. Parts ejection detector
3. Water removal unit
4. Beacon
5. Chip conveyer
6. Rotary magic guide bush unit
7. For pneumatic unit rotary magic guide bush
8. Main spindle inner tube
9. Non-guide bush type
10. Parts ejector (Air cylinder type)
11. Spacer set
12. Parts ejector (Spring type)
13. Parts ejector with guide tube
14. Parts stopper unit
15. Coolant unit (6.9MPa / 2.5MPa / 0.7MPa)
16. Coolant tank large capacity type
17. Coolant unit signal cable
18. Coolant unit power cable
19. Coolant valve (6.9MPa / 2.5MPa)
20. Coolant pipings
21. Automatic bar feeder interface
22. Compliant with the RS-232C interface
23. LAN interface
24. Transformer CE marking version
25. Transformer CE marking cable
26. CE marking version

Note)

The machining capacities apply to SUS303 material. The machining capacities may differ from listed values depending on the machining conditions, such as the material to be machined or the tools to be used.