



SWISS TYPE AUTOMATIC LATHE equipped with star motion control system 

# SV-20R





# SV INNOVAT

01 Outstanding capability and flexibility for the machining of complex mill turn components. The most advanced  $\phi 20$ -class model in the SV series has been upgraded from every angle to enable the user to manufacture even the most complicated components

The latest upgrade of the ever popular SV-20 offers even more functionality, capability and productivity for mill





**B axis control + Back working Y axis control  
Equipped with the Star Motion Control function,  
higher speed and larger variety of complex  
machining is achieved.**

#### F E A T U R E

- 8-position turret type tool post equipped with a B axis control mechanism enables simultaneous 5-spindle machining of complicated shape parts and angle hole machining.
- 8-spindle back working unit with additional Y-axis function ensures the maximum overlapping of operations to further improve machine output.
- The G.B./N.G.B. function provides the user with the ability to maximize part manufacture per bar.
- Tool post structure suited for flexible overlap machining and Star Motion Control function contributes to the further reduction of non-cutting time.



SWISS TYPE AUTOMATIC LATHE  
equipped with star motion control system

# SV-20R

# ION

turn components.

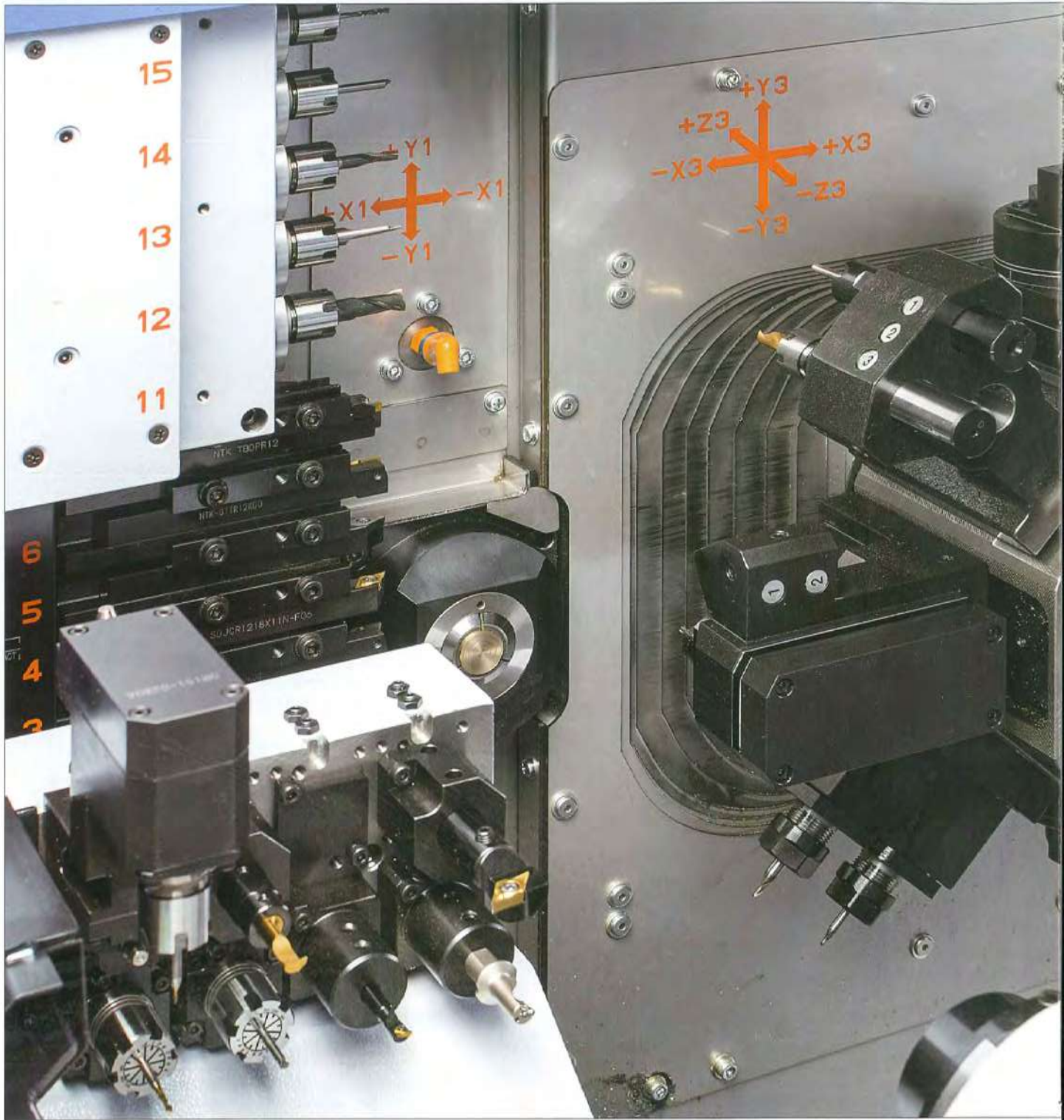

Complex machining capability for the manufacture of components for the Medical, Aerospace and Automotive industries.





## Gang type + 8-position turret-type + Back working tool post

The layout provides the User with multiple tooling options and unrivalled overlapping functions.

Gang-type tool post + 8-position turret-type tool post with B axis control + Back working 8-spindle unit with Y axis control and the Star Motion Control for high-level complex machining and superb productivity. The G.B./N.G.B. switching function for flexible response to the varied part shape. The combination of the machine design and expanded support software contributes to improved ease of operation and further increases machine output. Performance required for parts machining today are thoroughly explored from every angle to achieve the latest and the best model in the SV series. SV-20R, the model for the next generation of complex small part machining.

# SV-20R

CNC SWISS TYPE AUTOMATIC LATHE  
equipped with Star motion control system

Control method : CNC control by Star motion control system

Machine composition :

- Main spindle
- Sub spindle
- Gang type Tool post
- Turret type Tool post
- Backworking 8-spindle unit with Y-axis control

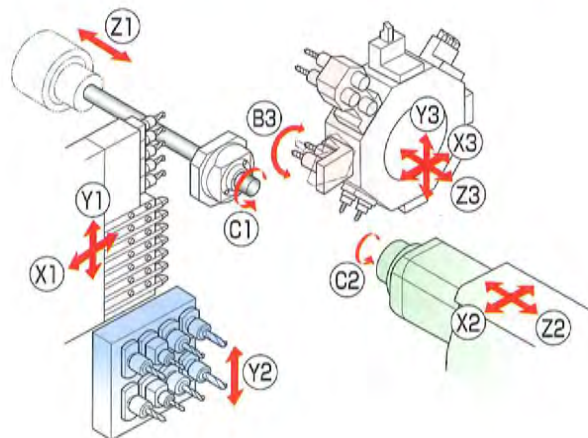

Illustration of tool layout : Guide bush type

## TOOLING SYSTEM

■ Gang type Tool post	Turning tool	6 tools (□16mm), 7 tools (□12mm)
	Power-driven tool	5 tools
■ Turret type Tool post	Turning tool	1 tools / station (□16mm) max. 3 tools / station (□12mm)
	Sleeve	max. 3 tools / station
	Power-driven tool	max. 2 tools / station
	Back 8-spindle unit	Stationary tool
	Power-driven tool	



# Improvement in High Functionality and Machining Capability



## 8-position turret-type tool post with B axis control mechanism

2-spindle power tool unit for B axis control can be mounted on a maximum of 4 positions on the turret-type tool post. Machining of inclined surfaces including angular holes on both the front and the back side is possible. Simultaneously controlled 5-spindle machining is possible.

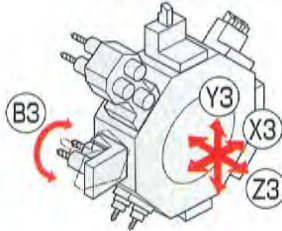

## G.B./N.G.B. switching function

The type best suited to any size of workpiece is selectable from the G.B. and the N.G.B.

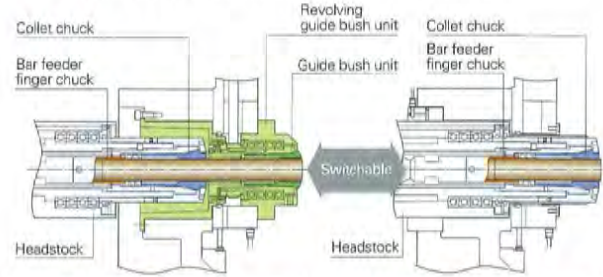

### Guide bush type

Highly accurate machining of motor shafts and other long parts by suppressing material deflection with the G.B. type.

### Non-guide bush type

The N.G.B. type for machining nuts and other short parts with less residual materials to reduce material costs and increase output.



## Back working 8-spindle unit with Y axis control function specially for back machining

Back working tool post with Y axis control to mount a power tool unit to accommodate a maximum of 8 tools.

A back working 8-spindle unit is mounted as standard. Various power tool units are also available for versatile complex machining on the rear side.

By combining with the sub spindle with 2-axis (X, Y) control function, three dimensional machining is possible.

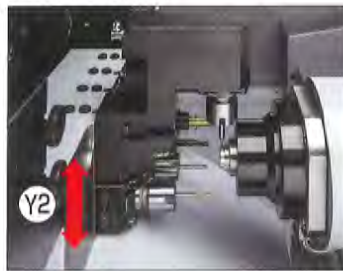

## Tool stations maximum of 28 pos.

Compared with SV-20, the number of tools to mount is increased by max. 12 to allow a larger variety of tooling layouts.

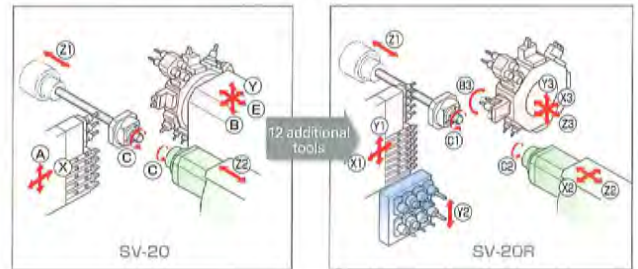

# Achievement in High Rigidity and High Accuracy



## A high rigid spindle sleeve slide guideway structure for N.G.B. type

The N.G.B type employs a spindle sleeve slide guideway structure to support the cutting force on the guideway, thus suppressing spindle deflection and realizing accurate machining. Rigidity of the headstock is ensured and continuous machining with stable accuracy is achieved.

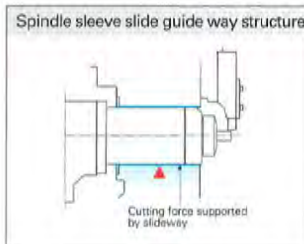
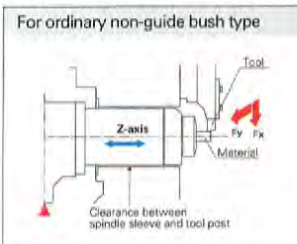

## A built-in spindle for high indexing accuracy

The main and sub spindle employ a built-in structure to enhance spindle indexing accuracy with a built-in sensor.



## Suppression of thermal displacement

The X2, X3 and Y3 axes are equipped with a thermal displacement correction switch each for correcting thermal displacement based on the measurement results.

In search of high functionality, accuracy and productivity from every angle





## Improvement in Operability and Workability



### Machine design in consideration of setup & maintenance works

- ① A cutting chamber uses a large-opening (1,154mm), flip-up door. SV-20 : 463mm ⇒ SV-20R : 1,154mm
- ② The headstock chamber employs a link-type door which opens upward of the machine to realize a larger opening. SV-20 : 390mm ⇒ SV-20R : 772mm

### Fulfilling operation support software

- ① "Center height adjustment function" to enable measurement of the tool center height on the gang edge side by handle operation.
- ② "Spindle synchro phase adjustment function" for simple operation by only following the guidance displayed on the NC screen.
- ③ "Multi-path program control function" for reduction of input/output operation by putting 3-path programs into one file.



## Pursuit of High Productivity

### Machining time reduction (mechanical system)

#### Simultaneous machining on gang type and turret type

Simultaneous machining of turning, milling, etc. by combining the gang type and turret type tool posts to realize reduced cutting time.



#### Flexible overlap machining

The 8-spindle unit with Y-axis control for back working can accommodate a maximum of eight power tools of various kinds. A wider variety of back working allows efficient front-/rear-end overlap machining. Cutting time is also reduced by optimized process division.



#### Higher output power of power tool motor

The power tool motor used for the gang-type tool post has high output power. (SV-20 : 0.5kW ⇒ SV-20R : 2.2kW)

#### Improvement in rapid feed

Improvement in rapid feed; Z axis feed on the main and sub spindle: 30m/min, X/Y axis on the gang-type tool post: 30m/min, X/Z axis on the turret-type tool post: 30m/min, Y axis: 15m/min.

### Machining time reduction (control system)



By the program optimization, the time required for the processes of [Disengagement], [Next tool selection] and [Approach] can be minimized to reduce the non-cutting time.

#### Star motion control system on board

Reduction of non-cutting time for switching the control system, changing tools, etc.

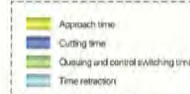

#### Concept of reduction of non-cutting time

##### Conventional CNC-controlled machining



##### Machining through Star motion control system



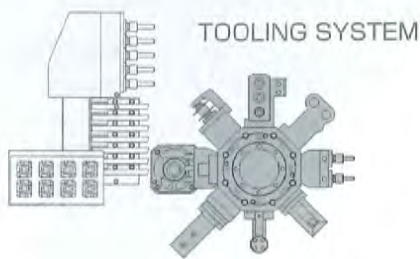

## Turret type Tool post

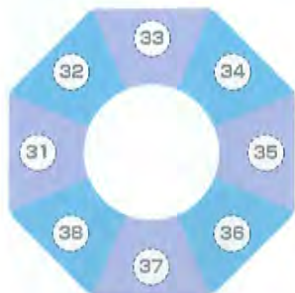

### Tool unit (turret side)

On-board unit	Mountable positions	
Fixed type tool holder	●	●
Fixed type tool holder (for 3 tools)	●	●
Center adjustable tool holder	●	●
3-spindle sleeve holder	●	●
1-spindle sleeve holder	●	●
1-spindle sleeve holder (for deep hole)	●	●
2-spindle programmable drilling unit	●	●*
1-spindle face drilling unit	●	●
2-spindle face drilling unit	●	●
Opposing type face drilling unit	●	●
2-spindle opposing type face drilling unit	●	●
Cross drilling unit	●	●
2-spindle cross drilling unit	●	●
2-spindle rapid feed cross drilling unit	●	●
Slotting unit	●	●
Angular adjustable drilling unit	●	●*
2-spindle angular adjustable drilling unit	●	●*
Polygon machining unit	●	●
Thread milling unit	●	●
Thread whirling unit	●	●

## Best tooling system to cover a wide range of machining needs



Fixed type tool holder (for 3 tools)



3-spindle sleeve holder



1-spindle sleeve holder (for deep hole)



2-spindle programmable drilling unit



2-spindle angular adjustable drilling unit



Thread milling unit



2-spindle cross drilling unit



2-spindle face drilling unit



Polygon machining unit



Slotting unit



Thread whirling unit

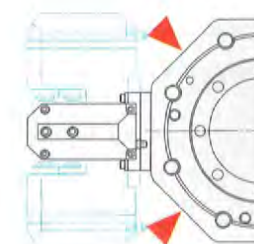

\* When mounting a unit on both neighboring positions, the swivel angle is limited.



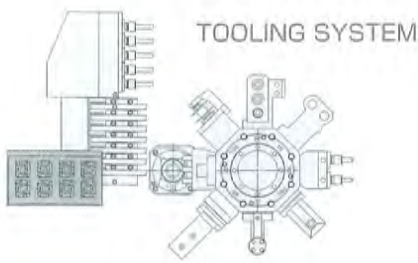

## 8-spindle unit for back working



- \* Two cross drilling units and two slotting units can be mounted, (on positions not adjoining).
- \* By mounting a quad-speed unit, the maximum rotation speed of other power tool units is clamped at 5000min<sup>-1</sup>.

 Power driven tools (on the back side) / Stationary tools (on the back side)

### Power driven tools (on the back side)

On-board unit	Mountable positions
	       

Drill sleeve ER16

	   
---	---

Oil hole drilling type back working unit

	   
---	---

Cross drilling unit \*

	   
---	---

Slotting unit \*

### Stationary tools (on the back side)

On-board unit	Mountable positions
	       

Drill sleeve ER20

	       
--	--

Bowling sleeve

	   
--	---

Quad-speed milling unit

An abundant line-up of tooling units for milling, cross drilling and slotting as 8-spindle back working units is available. This expands the availability of machining variations by allowing selection of the most appropriate tooling layout suited to user needs.

# Machining Capabilities to Meet Diversified Needs for Parts Machining.

VARIATION 01

**Front-end working**  
Opposing cross machining

09

VARIATION 02

**Front-end working**  
Back slanting machining with B-axis power tools

12

11

VARIATION 03

**Front-end working + Rear-end working**  
Main / back simultaneous machining



VARIATION 04

Rear-end working  
Back cross machining

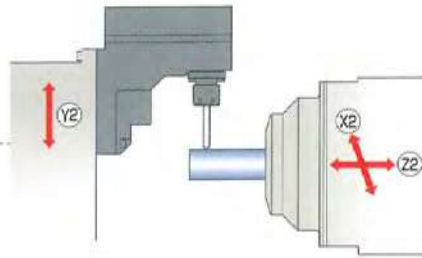

VARIATION 05

Rear-end working  
Back eccentric drilling

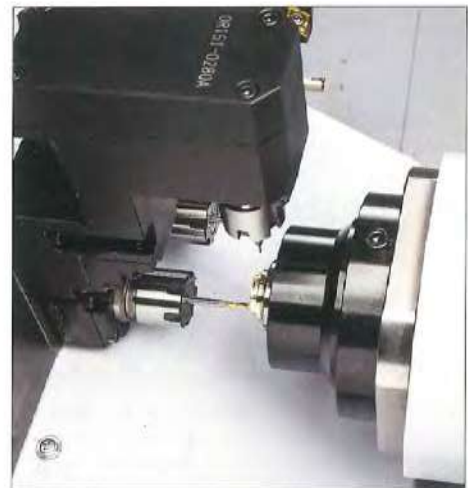
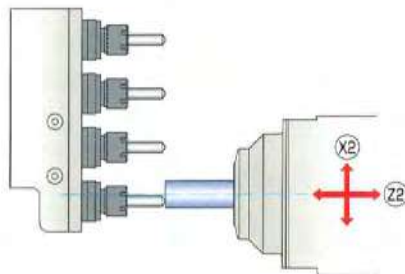

VARIATION 06

Rear-end working  
Back slanting machining with B-axis power tools

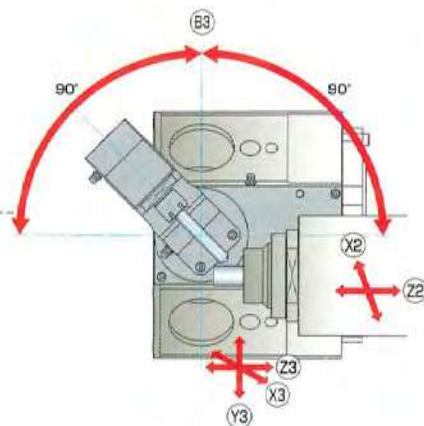

## Standard Machine Specifications

Item		Specifications
Max. machining diameter		φ 20mm(25/32in) OP: φ 23mm(29/32in)
Max. headstock stroke	Standard	205mm(8in)
	R.M.G.B. type	160mm(6-19/64in) . OP
	N.G.B. type	Bar diameter×2.5(Max.50mm)(Max.1-31/32in)
Tool post configuration	Gang type	Turning tool + Power-driven tool
	Turret type	8 stations
Tool	Gang type	6 tools(□16mm), 7 tools(□12mm)
	Turret type	1 tool / station(□16mm), Max.3tools / station(□12mm)
Sleeve	Number of tools	Max.3tools / station
	Max. drilling capability	φ 14mm(35/64in)
Power driven attachment	Max. tapping capability	M12×P1.75
	Number of tools	5 tools
Power driven attachment	Gang type	Max.2tools / station(mountable at each 8 positions)
	Turret type	Max.2tools / station(mountable at each 8 positions)
	Max. drilling capability	Gang type φ 10mm(25/64in) Turret type φ 10mm(25/64in)
	Max. tapping capability	Gang type M8×P1.25 Turret type M8×P1.25
	Spindle speed	Gang type Max.8,000min <sup>-1</sup> Turret type Max.5,750min <sup>-1</sup>
	Drive motor	Gang type 2.2kW Turret type 2.7kW(continuous) / 4.0kW(5min. / 30%ED)
Rapid feed rate		30m/min(X1,X2,X3,Y1,Z1,Z2,Z3) 20m/min(Y2),15m/min(Y3)
Main spindle indexing angle		C-axis control
Main spindle speed		Max.10,000min <sup>-1</sup>
Main spindle motor		3.7kW(continuous) / 5.5kW(10min. / 60%ED)
Coolant tank capability		220 ℓ
Dimensions (WxDxH)		2,730×1,350×1,865mm
Center height		1,125mm
Weight		4,150kg
Power consumption		6.3kVA

## Backworking Attachment Specifications

Item		Specifications	
Max. chucking diameter		φ 20mm(25/32in) OP: φ 23mm(29/32in)	
Max. length for front ejection		105mm(4-9/64in)	
Max. parts projection length		75mm(2-61/64in)	
Back 8-spindle unit	Number of tools	Stationary tool	8 tools
		Power driven tool	Max.8 tools
	Max. drilling capability	Stationary tool	φ 12mm(1/2in)
		Power driven tool	φ 6mm(15/64in)
	Max. tapping capability	Stationary tool	M10×P1.5
		Power driven tool	M5×P0.8
Power-driven att. spindle speed		Max.8,000min <sup>-1</sup>	
Power-driven att. drive motor		1.0kW(continuous) / 1.2kW(5min. / 30%ED)	
Sub spindle indexing angle		C-axis control	
Sub spindle speed		Max.10,000min <sup>-1</sup>	
Sub spindle motor		2.2kW(continuous) / 3.7kW(10min. / 40%ED)	

## External Dimensions and Floor Space

Unit : mm(ft)

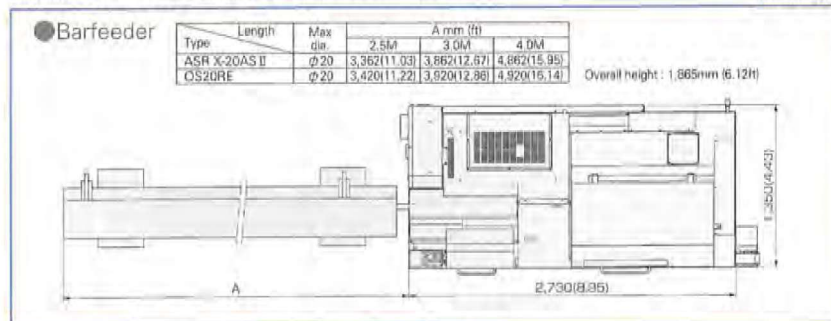

# STAR MICRONICS CO., LTD.

## Machine Tools Division

1500-34 Kitanoya, Misawa, Kikugawa, Shizuoka, 439-0023 Japan

America, Europe Sales TEL:+81-537-36-5594 FAX:+81-537-36-5607  
Asia Sales TEL:+81-537-36-5574 FAX:+81-537-36-5607

Star CNC Machine Tool Corporation  
123 Powerhouse Road, Roslyn Heights, NY 11577, U.S.A.  
TEL:+1-516-484-0500 FAX:+1-516-484-5820

Star Micronics GB Limited  
Unit 1 Riverlands Business Park Raynesway DERBY DE21 7BZ  
TEL:+44-1332-86-44-55 FAX:+44-1332-86-40-05

Star Micronics GmbH  
Robert-Grob-Str.1,D-75305 Neuenburg,Germany  
TEL:+49-7082-7920-0 FAX:+49-7082-7920-20

Star Micronics AG  
Lautstrasse3,CH-8112 Otelfingen,Switzerland  
TEL:+41-43-411-60-60 FAX:+41-43-411-60-66

Star Machine Tool France  
90 Allée de Glaisy,ZI 74300 Theyez Haute Savoie,France  
TEL:+33-450-96-05-97 FAX:+33-450-96-91-54

Shanghai Xingang Machinery Co.,Ltd.  
2F, 228 Fute Rd.N. The China (Shanghai) Pilot Free Trade Zone  
TEL:+86-21-5868-2100 FAX:+86-21-5868-2101

Star Micronics (Thailand) Co.,Ltd.  
289/23 M 13 Soi Kingkaew 25/1, Kingkaew Rd.,T.Rachathewi A,Bangplee Samulprakam 10540,Thailand  
TEL:+66-2-188-8945-47 FAX:+66-2-183-7845

<http://www.star-m.jp/eng/>

**9001 ISO 14001**  
CERTIFIED

※Design features, specifications and technical execution are subject to change without prior notice.

※This product is an export control item subject to the foreign exchange and foreign trade laws. Thus, before exporting this product, or taking it overseas, contact your STAR MICRONICS dealer.



**AMT Machine Tools LTD.**  
Canadian Distributor

73 Galaxy Blvd. Units 16 & 17, Rexdale, Ontario - M9W 5T4  
Office: 416-675-7760 | Fax: 416-675-6988  
[www.AMTmachine.com](http://www.AMTmachine.com) | [sales@amtmachine.com](mailto:sales@amtmachine.com)

2018.07\_Ver1.0\_1